

Cap Screws & Bolts

Hex Washer Frame Bolts

Grade 8 &
18-8 Stainless

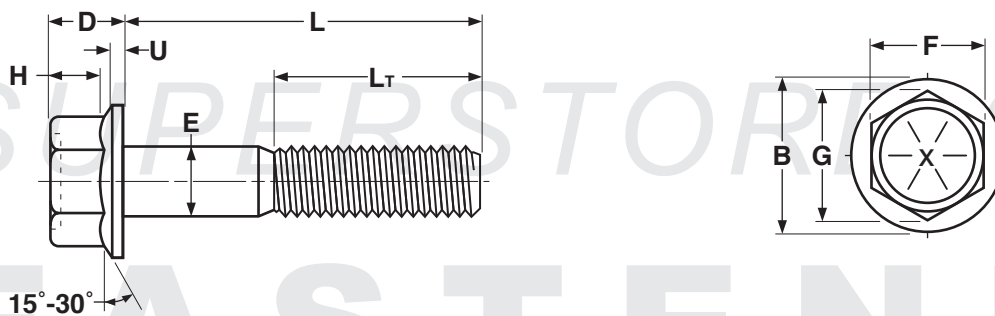

±Length of a frame bolt is measured from the underhead bearing surface to the extreme end of the screw.

FRAME BOLTS / FLANGE BOLTS													IFI 111 & SAE J429	
Nominal Size	E		F			G		B	U	D	H	L _T	Gr-8 Alloy Bolts Only	
	Body Diameter		Width Across Flats			Width Across Corners		Flange Diam.	Flange Thick-ness	Head Height	Hex Height	Thread Length	Tensile Strength, Lbs.	Proof Load, Lbs.
	Max	Min	Basic	Max	Min	Max	Min	Max	Min	Max	Min	Basic		
1/4	0.2500	0.2450	3/8	0.3750	0.367	0.433	0.409	0.56	0.04	0.28	0.17	0.750	4,750	3,800
5/16	0.3125	0.3065	1/2	0.5000	0.489	0.577	0.548	0.68	0.05	0.32	0.21	0.875	7,850	6,300
3/8	0.3750	0.3690	9/16	0.5625	0.551	0.650	0.618	0.81	0.06	0.425	0.25	1.000	11,600	9,300
7/16	0.4375	0.4305	5/8	0.6250	0.612	0.722	0.685	0.93	0.07	0.46	0.30	1.125	15,900	12,800
1/2	0.5000	0.4930	3/4	0.7500	0.736	0.866	0.825	1.07	0.08	0.555	0.34	1.250	21,300	17,000
5/8	0.6250	0.6170	15/16	0.9375	0.922	1.083	1.034	1.33	0.10	0.690	0.42	1.500	33,900	27,100
3/4	0.7500	0.7410	1-1/8	1.1250	1.100	1.299	1.234	1.59	0.11	0.825	0.51	1.750	50,100	40,100

Tolerance on Length	Nominal Bolt Size	Nominal Bolt Length		
		Up to 1 in., incl.	Over 1 in. to 2-1/2 in., incl.	Over 2-1/2 in. to 4 in., incl.
	1/4 to 3/8	-0.03	-0.04	-0.06
	7/16 and 1/2	-0.03	-0.06	-0.08
5/8 and 3/4	-0.03	-0.08	-0.10	

Description	A one-piece indented hex-washer head bolt with a flat bearing surface, made of high-alloy steel.	A one-piece indented hex-washer head bolt with a flat bearing surface, made of stainless steel.
Applications/ Advantages	For use on truck frames. The flange eliminates washers and helps compensate for a misaligned hole. Used with a Grade-GT lock nut, the bolt system resists bolt slippage by distributing the clamp load over a wide area.	Used in applications where greater resistance to corrosion is required and increased bearing area is desired.
Material	AISI 4037 - 5135 or equivalent alloy steel	18-8 Stainless Steel
Heat Treatment	Grade-8 frame bolts shall be heat-treated, oil-quenched and tempered at a minimum temperature of 800°F.	-
Core Hardness	Rockwell C33 - C39	Overall Hardness:
Surface Hardness	Rockwell 30N58.6 maximum	1/4 thru 5/8" diameters: Rockwell B95 - C32 3/4 thru 1 1/2" diameters: Rockwell B80 - C32
Proof Load	120,000 psi.	-
Yield Strength	130,000 psi. minimum	1/4 thru 5/8" diameters: 65,000 psi. 3/4 thru 1 1/2" diameters: 45,000 psi.
Tensile Strength	150,000 psi. minimum	1/4 thru 5/8" diameters: 100,000 - 150,000 psi. 3/4 thru 1 1/2" diameters: 85,000 - 140,000 psi.
Coating	See Appendix-A for information on the plating of frame bolts.	Stainless flange bolts are usually supplied with no additional finish.

**Product standards require the manufacturer's head marking to appear on the top of all steel bolts 1/4" diameter and larger.

"X" represents one location such a marking may appear.

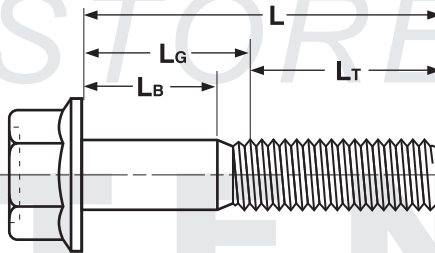

HEX WASHER FRAME BOLTS														IFI-111 2002	
Maximum Grip Gaging Lengths, L_G , and Minimum Body Lengths, L_B															
Nominal Diameter	1/4		5/16		3/8		7/16		1/2		5/8		3/4		
Nominal Lengths	LB Min	LG Max	LB Min	LG Max	LB Min	LG Max	LB Min	LG Max	LB Min	LG Max	LB Min	LG Max	LB Min	LG Max	
1-1/4															
1-3/8	0.225	0.625													
1-1/2	0.350	0.750	0.208	0.625											
1-5/8	0.475	0.875	0.333	0.750	0.187	0.625									
1-3/4	0.600	1.000	0.458	0.875	0.312	0.750									
1-7/8	0.725	1.125	0.583	1.000	0.437	0.875	0.286	0.750							
2	0.850	1.250	0.708	1.125	0.562	1.000	0.411	0.875	0.269	0.750					
2-1/8	0.975	1.375	0.833	1.250	0.687	1.125	0.536	1.000	0.394	0.875					
2-1/4	1.100	1.500	0.958	1.375	0.812	1.250	0.661	1.125	0.519	1.000					
2-3/8	1.225	1.625	1.083	1.500	0.937	1.375	0.786	1.250	0.644	1.125					
2-1/2	1.350	1.750	1.208	1.625	1.062	1.500	0.911	1.375	0.769	1.250					
2-5/8	1.475	1.875	1.333	1.750	1.187	1.625	1.036	1.500	0.894	1.375	0.352	1.125			
2-3/4	1.600	2.000	1.458	1.875	1.312	1.750	1.161	1.625	1.019	1.500	0.477	1.250			
2-7/8	1.725	2.125	1.583	2.000	1.437	1.875	1.286	1.750	1.144	1.625	0.602	1.375	0.325	1.125	
3	1.850	2.250	1.708	2.125	1.562	2.000	1.411	1.875	1.269	1.750	0.727	1.500	0.450	1.250	
3-1/4	2.100	2.500	1.958	2.375	1.812	2.250	1.661	2.125	1.519	2.000	0.977	1.750	0.700	1.500	
3-1/2	2.350	2.750	2.208	2.625	2.062	2.500	1.911	2.375	1.769	2.250	1.227	2.000	0.950	1.750	
3-3/4	2.600	3.000	2.458	2.875	2.312	2.750	2.161	2.625	2.019	2.500	1.477	2.250	1.200	2.000	
4	2.850	3.250	2.708	3.125	2.562	3.000	2.411	2.875	2.269	2.750	1.727	2.500	1.450	2.250	
4-1/4	3.100	3.500	2.958	3.375	2.812	3.250	2.661	3.125	2.519	3.000	1.977	2.750	1.700	2.500	
4-1/2	3.350	3.750	3.208	3.625	3.062	3.500	2.911	3.375	2.769	3.250	2.227	3.000	1.950	2.750	
4-3/4	3.60	4.000	3.458	3.875	3.312	3.750	3.161	3.625	3.019	3.500	2.477	3.250	2.200	3.000	
5	3.850	4.250	3.708	4.125	3.562	4.000	3.411	3.875	3.269	3.750	2.727	3.500	2.450	3.250	

Frame Bolt lengths above heavy black line are fully threaded (for parts made after 2002)