

# SR05 Series 5V 25A Diode Array

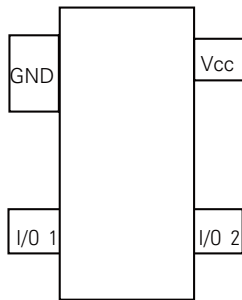

## Pinout



## Functional Block Diagram

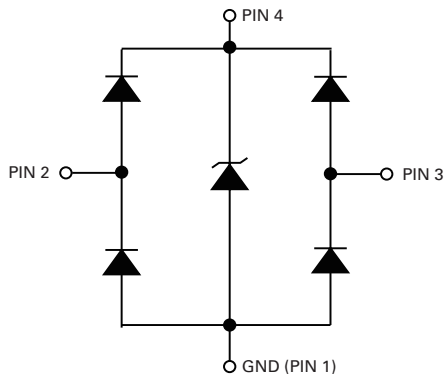

Life Support Note:  
**Not Intended for Use in Life Support or Life Saving Applications**  
The products shown herein are not designed for use in life sustaining or life saving applications unless otherwise expressly indicated.

## Description

The SR05 consists of four, low capacitance steering diodes and a low voltage TVS diode that provide protection against ESD and lightning surge events. Each channel or I/O pin can safely absorb up to 25A ( $t_p=8/20\mu s$ ) and repetitive ESD strikes above the maximum level (Level 4) specified in the IEC 61000-4-2 international standard without performance degradation.

The low loading capacitance makes it ideal for protecting high-speed telecommunication data lines.

## Features

- ESD, IEC61000-4-2 ,  $\pm 30kV$  contact discharge,  $\pm 30kV$  air discharge
- EFT, IEC61000-4-4, 80A ( $t_p=5/50ns$ )
- Lightning protection, IEC61000-4-5, 25A ( $t_p=8/20\mu s$ )
- Low capacitance of 6.0pF (TYP) per I/O
- Low clamp voltage
- Small SOT143 (JEDEC TO-253) packaging

## Applications

- T1/E1 IC/Secondary Protection
- Ethernet 10BaseT
- WAN/LAN Equipment
- ISDN S/T Interface
- Video Lines
- Microcontroller Input Protection

## Application Example

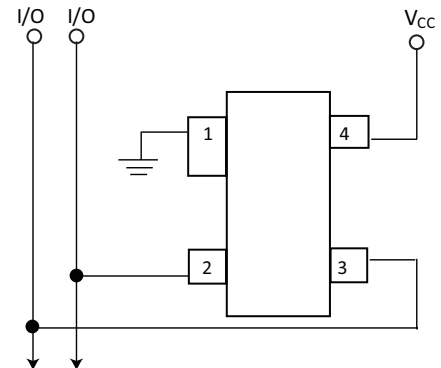

The SR05 integrates a TVS Diode between the Vcc and Gnd pins. This allows the array to protect the power supply against ESD and lightning surges when these pins are both connected in the application.

SR05

### Absolute Maximum Ratings

Symbol	Parameter	Value	Units
$I_{PP}$	Peak Current ( $t_p=8/20\mu s$ )	25.0	A
$P_{PK}$	Peak Pulse Power ( $t_p=8/20\mu s$ )	450	W
$T_{OP}$	Operating Temperature	-40 to 125	°C
$T_{STOR}$	Storage Temperature	-55 to 150	°C

CAUTION: Stresses above those listed in "Absolute Maximum Ratings" may cause permanent damage to the device. This is a stress only rating and operation of the device at these or any other conditions above those indicated in the operational sections of this specification is not implied.

### Thermal Information

Parameter	Rating	Units
Storage Temperature Range	-55 to 150	°C
Maximum Junction Temperature	150	°C
Maximum Lead Temperature (Soldering 20-40s)	260	°C

### Electrical Characteristics ( $T_{OP}=25^\circ C$ )

Parameter	Symbol	Test Conditions	Min	Typ	Max	Units
Reverse Stand-Off Voltage	$V_{RWM}$		-	-	5.0	V
Reverse Leakage Current	$I_R$	$V_R = 5V$ , I/O to GND	-	-	5.0	$\mu A$
Reverse Breakdown Voltage	$V_{BR}$	$I_t = 1mA$	6.0	-	-	V
Clamping Voltage, Line-Ground <sup>1</sup>	$V_C$	$I_{PP} = 1A$ , $t_p = 8/20 \mu s$	-	-	9.8	V
Clamping Voltage, Line-Ground <sup>1</sup>	$V_C$	$I_{PP} = 10A$ , $t_p = 8/20 \mu s$	-	-	12.0	V
Clamping Voltage, Line-Ground <sup>1</sup>	$V_C$	$I_{PP} = 25A$ , $t_p = 8/20 \mu s$	-	-	18.0	V
Dynamic Resistance, Line-Ground <sup>1</sup>	$R_{DYN}$	$(V_{C2} - V_{C1}) / (I_{PP2} - I_{PP1})$	-	0.3	-	$\Omega$
ESD Withstand Voltage <sup>1</sup>	$V_{ESD}$	IEC61000-4-2 (Contact Discharge)	$\pm 30$	-	-	kV
		IEC61000-4-2 (Air Discharge)	$\pm 30$	-	-	kV
Diode Capacitance <sup>1</sup>	$C_{I/O-I/O}$	Reverse Bias=0V	-	3.0	-	pF
	$C_{I/O-GND}$	Reverse Bias=0V	-	6.0	10.0	pF

Note: 1. Parameter is guaranteed by design and/or device characterization.

### Capacitance vs. Reverse Bias

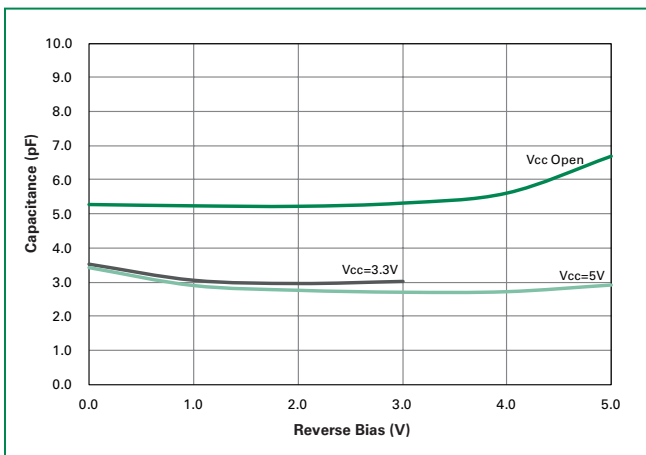

### Pulse Waveform

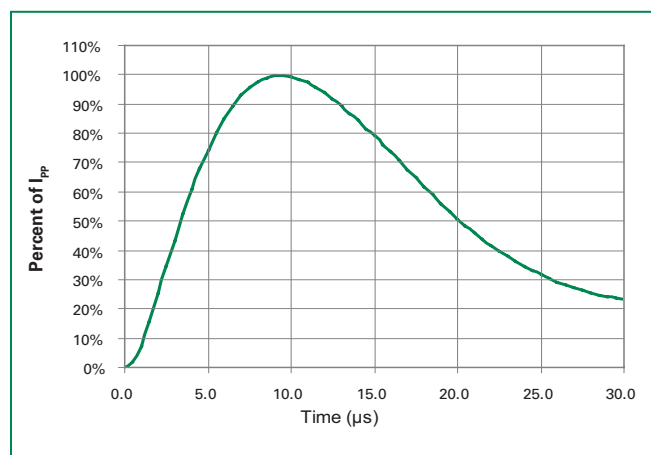

### Clamping Voltage vs. $I_{PP}$

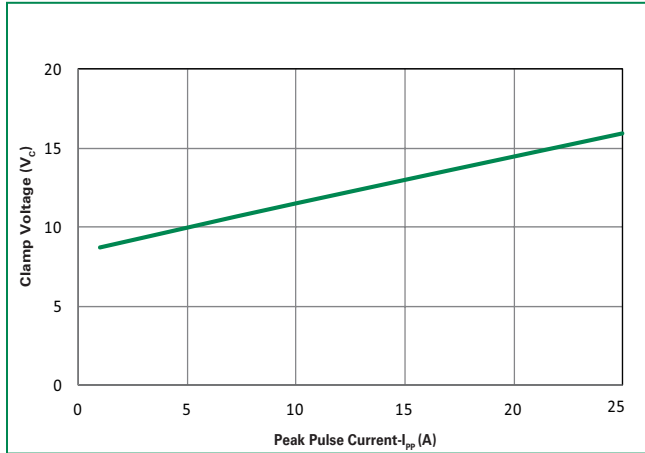

### Product Characteristics

<b>Lead Plating</b>	Matte Tin
<b>Lead Material</b>	Copper Alloy
<b>Lead Coplanarity</b>	0.0004 inches (0.102mm)
<b>Substitute Material</b>	Silicon
<b>Body Material</b>	Molded Epoxy
<b>Flammability</b>	UL 94 V-0

- Notes :
1. All dimensions are in millimeters
  2. Dimensions include solder plating.
  3. Dimensions are exclusive of mold flash & metal burr.
  4. Blo is facing up for mold and facing down for trim/form, i.e. reverse trim/form.
  5. Package surface matte finish VDI 11-13.

### Soldering Parameters

Reflow Condition	Pb – Free assembly	
Pre Heat	- Temperature Min ( $T_{s(min)}$ )	150°C
	- Temperature Max ( $T_{s(max)}$ )	200°C
	- Time (min to max) ( $t_s$ )	60 – 180 secs
Average ramp up rate (Liquidus) Temp ( $T_L$ ) to peak	3°C/second max	
$T_{s(max)}$ to $T_L$ - Ramp-up Rate	3°C/second max	
Reflow	- Temperature ( $T_L$ ) (Liquidus)	217°C
	- Temperature ( $t_l$ )	60 – 150 seconds
Peak Temperature ( $T_p$ )	260 <sup>+0/-5</sup> °C	
Time within 5°C of actual peak Temperature ( $t_p$ )	20 – 40 seconds	
Ramp-down Rate	6°C/second max	
Time 25°C to peak Temperature ( $T_p$ )	8 minutes Max.	
Do not exceed	260°C	

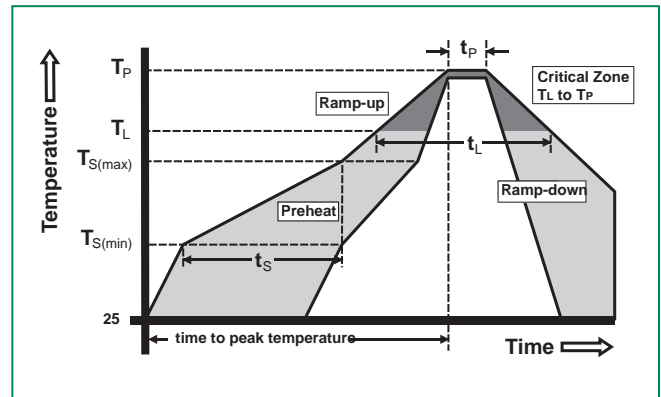

### Ordering Information

Part Number	Package	Marking	Min. Order Qty.
SR05-02CTG	SOT143	SR05	3000

### Part Numbering System

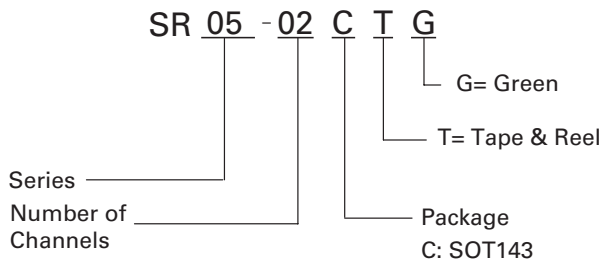

### Part Marking System

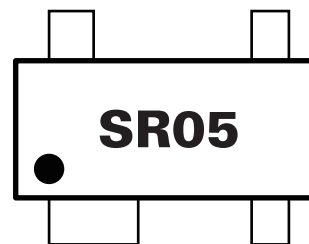

**Package Dimensions—SOT143**

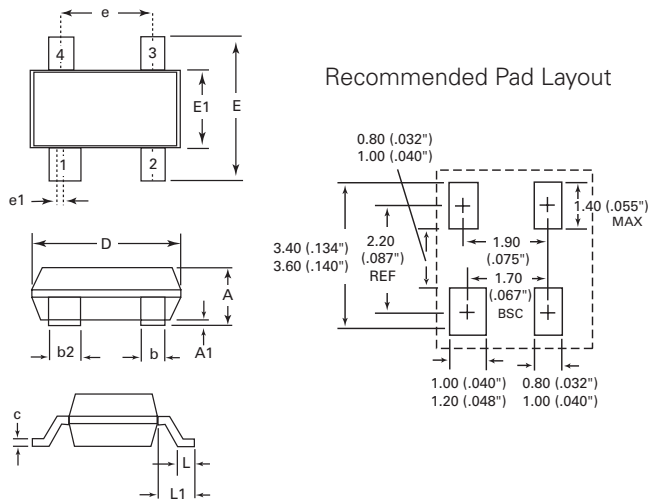

Package	SOT143			
Pins	4			
JEDEC	TO-253			
	Millimeters		Inches	
	Min	Max	Min	Max
<b>A</b>	0.8	1.22	0.03	0.048
<b>A1</b>	0.05	0.15	0.002	0.006
<b>b</b>	0.30	0.50	0.012	0.020
<b>b2</b>	0.76	0.89	0.030	0.035
<b>c</b>	0.08	0.20	0.003	0.008
<b>D</b>	2.80	3.04	0.110	0.120
<b>E</b>	2.10	2.64	0.082	0.104
<b>E1</b>	1.20	1.40	0.047	0.055
<b>e</b>	1.92 BSC		0.076 BSC	
<b>e1</b>	0.20 BSC		0.008 BSC	
<b>L</b>	0.4	0.6	0.016	0.024
<b>L1</b>	0.550 REF		0.022 REF	

**Embossed Carrier Tape & Reel Specification—SOT143**

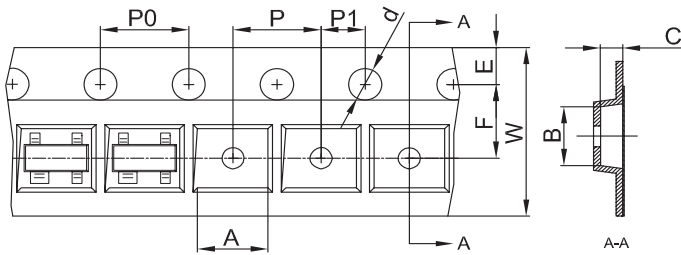

Symbol	Millimeters
<b>A</b>	3.19+/-0.10
<b>B</b>	2.8+/-0.10
<b>C</b>	1.31+/-0.10
<b>d</b>	∅ 1.50+/-0.10
<b>E</b>	1.75+/-0.10
<b>F</b>	3.50+/-0.10
<b>P0</b>	4.00+/-0.10
<b>P</b>	4.00+/-0.10
<b>P1</b>	2.00+/-0.10
<b>W</b>	8.00+/-0.10

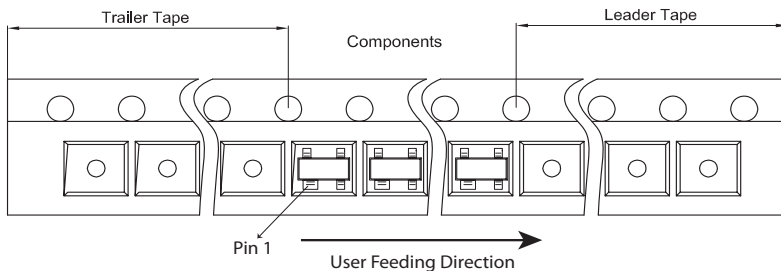

Notes:  
1. All dimensions are in millimeters

# Mouser Electronics

Authorized Distributor

Click to View Pricing, Inventory, Delivery & Lifecycle Information:

[Littelfuse:](#)

[SR05-02CTG](#)