

LQS

Snap-in Terminal type, 105°C High speed charge-discharge.



- Suited for high frequency regenerative voltage for AC servomotor, general inverter.
- Suited for equipment used at voltage fluctuating area.
- Suited for rectifier circuit of voltage doubler
- Compliant to the RoHS directive (2011/65/EU).

LQS

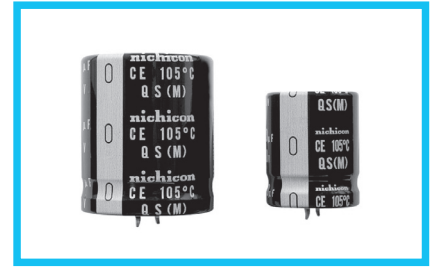

Specifications

Item	Performance Characteristics					
Category Temperature Range	- 25 to +105°C					
Rated Voltage Range	350 to 450V					
Rated Capacitance Range	82 to 820μF					
Capacitance Tolerance	±20% at 120Hz, 20°C					
Leakage Current	$I \leq 3\sqrt{C}$ (μA) (After 5 minutes' application of rated voltage [C: Rated Capacitance(μF), V: Voltage (V)])					
Tangent of loss angle (tan δ)	Measurement frequency : 120Hz at 20°C					
	Rated voltage (V)	350	400	420	450	
	tan δ (MAX.)	0.15	0.15	0.15	0.20	
Stability at Low Temperature	Rated voltage (V)		350 to 450		Measurement frequency : 120Hz	
	Impedance ratio ZT/Z20(MAX.)		Z - 25°C / Z+20°C			
			8			
Endurance of charge-discharge behavior	After an application of charge-discharge voltage for 50million times (charge-discharge voltage difference(ΔV) = rated voltage × 0.35, cycle 6Hz) capacitors shall meet the characteristics requirement listed at right.				Capacitance change	Within ±20% of the initial capacitance value
					tan δ	300% or less than the initial specified value
					Leakage current	Less than or equal to the initial specified value
					Appearance	There shall be found to remarkable abnormality on the capacitor
Endurance	The specifications listed at right shall be met when the capacitors are restored to 20°C after D.C. bias plus rated ripple current is applied for 3000 hours at 105°C, the peak voltage shall not exceed the rated voltage.				Capacitance change	Within ±20% of the initial capacitance value
					tan δ	200% or less than the initial specified value
					Leakage current	Less than or equal to the initial specified value
Shelf Life	After storing the capacitors under no load at 105°C for 1000 hours and then performing voltage treatment based on JIS C 5101-4 clause 4.1 at 20°C, they shall meet the specified value for endurance characteristics listed above.					
Marking	Printed with white color letter on black sleeve.					

Drawing

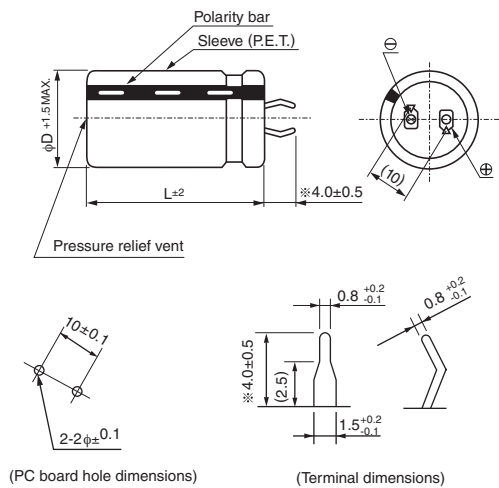

Type numbering system (Example : 400V 180μF)

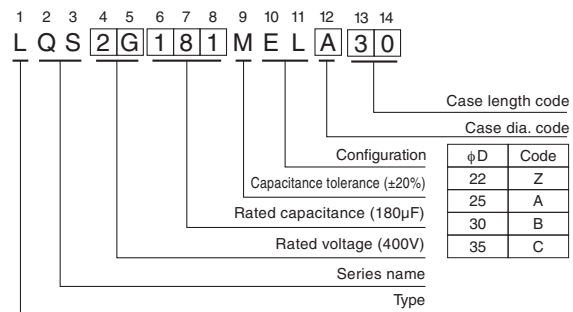

※ Please contact to us if other configurations are required.

※ The other terminal is also available upon request.
Please refer page 327 for schematic of dimensions.

Minimum order quantity : 50pcs.

● Dimension table in next page.



■ Dimensions

350V (2V)				
Cap. (μF)	Size φD × L (mm)	Rated ripple (mArms)	Leakage Current (mA)	Code
120	22 × 25	750	0.61	LQS2V121MELZ25
150	22 × 30	820	0.68	LQS2V151MELZ30
180	22 × 30	900	0.75	LQS2V181MELZ30
	25 × 25	900	0.75	LQS2V181MELA25
220	22 × 35	1000	0.83	LQS2V221MELZ35
	25 × 30	1000	0.83	LQS2V221MELA30
270	22 × 40	1100	0.92	LQS2V271MELZ40
	25 × 35	1100	0.92	LQS2V271MELA35
	30 × 25	1100	0.92	LQS2V271MELB25
330	22 × 45	1200	1.01	LQS2V331MELZ45
	25 × 40	1200	1.01	LQS2V331MELA40
	30 × 30	1200	1.01	LQS2V331MELB30
390	25 × 45	1300	1.10	LQS2V391MELA45
	30 × 35	1300	1.10	LQS2V391MELB35
470	25 × 50	1400	1.21	LQS2V471MELA50
	30 × 40	1400	1.21	LQS2V471MELB40
560	30 × 45	1500	1.32	LQS2V561MELB45
	35 × 35	1500	1.32	LQS2V561MELC35
680	30 × 50	1700	1.46	LQS2V681MELB50
	35 × 40	1700	1.46	LQS2V681MELC40
820	35 × 45	1900	1.60	LQS2V821MELC45

400V (2G)				
Cap. (μF)	Size φD × L (mm)	Rated ripple (mArms)	Leakage Current (mA)	Code
100	22 × 25	680	0.60	LQS2G101MELZ25
120	22 × 30	730	0.65	LQS2G121MELZ30
150	22 × 35	850	0.73	LQS2G151MELZ35
180	22 × 35	950	0.80	LQS2G181MELZ35
	25 × 30	950	0.80	LQS2G181MELA30
	30 × 25	950	0.80	LQS2G181MELB25
220	22 × 45	1100	0.88	LQS2G221MELZ45
	25 × 35	1100	0.88	LQS2G221MELA35
	30 × 25	1100	0.88	LQS2G221MELB25
	22 × 50	1220	0.98	LQS2G271MELZ50
270	25 × 40	1220	0.98	LQS2G271MELA40
	30 × 30	1220	0.98	LQS2G271MELB30
	35 × 25	1220	0.98	LQS2G271MELC25
330	25 × 45	1440	1.08	LQS2G331MELA45
	30 × 35	1440	1.08	LQS2G331MELB35
390	25 × 50	1550	1.18	LQS2G391MELA50
	30 × 40	1550	1.18	LQS2G391MELB40
	35 × 30	1550	1.18	LQS2G391MELC30
470	30 × 45	1680	1.30	LQS2G471MELB45
	35 × 35	1680	1.30	LQS2G471MELC35
560	30 × 50	1900	1.41	LQS2G561MELB50
	35 × 40	1900	1.41	LQS2G561MELC40
680	35 × 45	2120	1.56	LQS2G681MELC45

420V (W6)				
Cap. (μF)	Size φD × L (mm)	Rated ripple (mArms)	Leakage Current (mA)	Code
100	22 × 25	660	0.61	LQSW6101MELZ25
120	22 × 30	810	0.67	LQSW6121MELZ30
	25 × 25	810	0.67	LQSW6121MELA25
150	22 × 35	840	0.75	LQSW6151MELZ35
	25 × 30	840	0.75	LQSW6151MELA30
180	22 × 40	910	0.82	LQSW6181MELZ40
	25 × 30	910	0.82	LQSW6181MELA30
	30 × 25	910	0.82	LQSW6181MELB25
220	22 × 45	1050	0.91	LQSW6221MELZ45
	25 × 35	1050	0.91	LQSW6221MELA35
	30 × 30	1050	0.91	LQSW6221MELB30
270	25 × 40	1250	1.01	LQSW6271MELA40
	30 × 30	1250	1.01	LQSW6271MELB30
	35 × 25	1250	1.01	LQSW6271MELC25
330	25 × 50	1420	1.11	LQSW6331MELA50
	30 × 35	1420	1.11	LQSW6331MELB35
	35 × 30	1420	1.11	LQSW6331MELC30
390	30 × 40	1610	1.21	LQSW6391MELB40
	35 × 35	1610	1.21	LQSW6391MELC35
470	30 × 45	1860	1.33	LQSW6471MELB45
	35 × 40	1860	1.33	LQSW6471MELC40
560	35 × 45	2100	1.45	LQSW6561MELC45
680	35 × 50	2200	1.60	LQSW6681MELC50

450V (2W)				
Cap. (μF)	Size φD × L (mm)	Rated ripple (mArms)	Leakage Current (mA)	Code
82	22 × 25	640	0.57	LQS2W820MELZ25
100	22 × 30	690	0.63	LQS2W101MELZ30
	25 × 25	690	0.63	LQS2W101MELA25
120	22 × 35	720	0.69	LQS2W121MELZ35
	25 × 30	720	0.69	LQS2W121MELA30
150	22 × 40	790	0.77	LQS2W151MELZ40
	25 × 30	790	0.77	LQS2W151MELA30
	30 × 25	790	0.77	LQS2W151MELB25
180	22 × 45	870	0.85	LQS2W181MELZ45
	25 × 35	870	0.85	LQS2W181MELA35
	30 × 30	870	0.85	LQS2W181MELB30
220	25 × 40	1050	0.94	LQS2W221MELA40
	30 × 30	1050	0.94	LQS2W221MELB30
	35 × 25	1050	0.94	LQS2W221MELC25
270	25 × 50	1230	1.04	LQS2W271MELA50
	30 × 35	1230	1.04	LQS2W271MELB35
	35 × 30	1230	1.04	LQS2W271MELC30
330	30 × 40	1380	1.15	LQS2W331MELB40
	35 × 35	1380	1.15	LQS2W331MELC35
390	30 × 50	1610	1.25	LQS2W391MELB50
	35 × 40	1610	1.25	LQS2W391MELC40
470	35 × 45	1780	1.37	LQS2W471MELC45
560	35 × 50	1990	1.50	LQS2W561MELC50

Rated ripple current (mArms) at 105°C 120Hz

● Frequency coefficient of rated ripple current

Frequency (Hz)	50	60	120	300	1k	10k	50k or more
Coefficient	0.77	0.82	1.00	1.16	1.30	1.41	1.43

Mouser Electronics

Authorized Distributor

Click to View Pricing, Inventory, Delivery & Lifecycle Information:

Nichicon:

[LQS2V471MELB40](#) [LQSW6101MELZ25](#) [LQS2W331MELB40](#) [LQSW6221MELZ45](#) [LQS2W121MELZ35](#)
[LQSW6151MELA30](#) [LQS2G471MELB45](#) [LQS2G391MELA50](#) [LQS2W221MELA40](#) [LQSW6471MELC40](#)
[LQS2G151MELZ35](#) [LQS2V391MELA45](#) [LQSW6181MELZ40](#) [LQS2G331MELB35](#) [LQSW6471MELB45](#)
[LQS2W121MELA30](#) [LQS2V331MELZ45](#) [LQS2V221MELA30](#) [LQS2G221MELZ45](#) [LQS2W271MELA50](#)
[LQSW6271MELC25](#) [LQS2W820MELZ25](#) [LQSW6331MELC30](#) [LQS2V221MELZ35](#) [LQS2G121MELZ30](#)
[LQS2V271MELZ40](#) [LQSW6391MELB40](#) [LQS2W101MELA25](#) [LQS2G271MELC25](#) [LQS2W391MELC40](#)
[LQS2V181MELA25](#) [LQS2W151MELZ40](#) [LQS2W471MELC45](#) [LQS2V121MELZ25](#) [LQSW6221MELA35](#)
[LQS2G181MELZ35](#) [LQS2G271MELZ50](#) [LQS2W391MELB50](#) [LQSW6221MELB30](#) [LQS2V471MELA50](#)
[LQS2V151MELZ30](#) [LQS2W221MELC25](#) [LQS2V681MELC40](#) [LQS2V271MELB25](#) [LQS2G221MELB25](#)
[LQS2G181MELB25](#) [LQS2W181MELZ45](#) [LQSW6271MELB30](#) [LQS2W151MELB25](#) [LQS2G271MELB30](#)
[LQSW6331MELB35](#) [LQS2W271MELC30](#) [LQS2V561MELC35](#) [LQS2V821MELC45](#) [LQSW6181MELB25](#)
[LQS2G561MELC40](#) [LQS2G681MELC45](#) [LQS2V471MELC30](#) [LQS2V681MELB50](#) [LQSW6151MELZ35](#)
[LQS2G471MELC35](#) [LQS2W181MELB30](#) [LQSW6391MELC35](#) [LQS2G101MELZ25](#) [LQS2G181MELA30](#)
[LQS2W101MELZ30](#) [LQS2V331MELB30](#) [LQSW6181MELA30](#) [LQS2G221MELA35](#) [LQS2W561MELC50](#)
[LQS2G331MELA45](#) [LQS2W221MELB30](#) [LQSW6271MELA40](#) [LQS2V561MELB45](#) [LQSW6121MELZ30](#)
[LQS2V181MELZ30](#) [LQS2W271MELB35](#) [LQS2G391MELC30](#) [LQSW6681MELC50](#) [LQS2G561MELB50](#)
[LQS2V271MELA35](#) [LQS2V331MELA40](#) [LQS2G271MELA40](#) [LQS2W331MELC35](#) [LQSW6331MELA50](#)
[LQS2W181MELA35](#) [LQSW6121MELA25](#) [LQS2G391MELB40](#) [LQSW6561MELC45](#) [LQS2W151MELA30](#)
[LQS2V391MELB35](#)