

ALUMINUM ELECTROLYTIC CAPACITORS

UUJ

Chip Type, Higher Capacitance Range



For SMD



Long Life



Anti-Solvent Feature (Through 100V only)

- Chip Type, higher capacitance in larger case sizes ($\phi 12.5$, $\phi 16$, $\phi 18$)
- Designed for surface mounting on high density PC board.
- Applicable to automatic mounting machine fed with carrier tape and tray.
- Compliant to the RoHS directive (2011/65/EU).

UUJ

Bi-Polarized

UUN



Specifications

Item	Performance Characteristics										
Category Temperature Range	-55 to +105°C (6.3 to 100V), -40 to +105°C (160 to 450V)										
Rated Voltage Range	6.3 to 450V										
Rated Capacitance Range	3.3 to 6800 μ F										
Capacitance Tolerance	$\pm 20\%$ at 120Hz, 20°C										
Leakage Current	Rated voltage (V)	6.3 to 100							160 to 450		
	—	After 1 minute's application of rated voltage, leakage current is not more than 0.03CV or 4 (μ A), whichever is greater.							I = 0.04CV+100 (μ A) max. (1 minute's)		
Tangent of loss angle (tan δ)	Measurement frequency : 120Hz at 20°C										
	Rated voltage (V)	6.3	10	16	25	35	50	63	100	160 to 250	400 - 450
	tan δ (MAX.)	0.26	0.22	0.18	0.16	0.14	0.12	0.10	0.08	0.15	0.20
For capacitance of more than 1000 μ F, add 0.02 for every increase of 1000 μ F.											
Stability at Low Temperature	Measurement frequency: 120Hz										
	Rated voltage (V)	6.3	10	16	25	35	50	63	100	160 to 250	400 - 450
	Impedance ratio Z-25°C / Z+20°C	5	4	3	2	2	2	2	2	2	3
ZT / Z20 (MAX.)	Z-40°C / Z+20°C	10	8	6	4	3	3	3	3	6	10
Endurance	The specifications listed at right shall be met when the capacitors are restored to 20°C after the rated voltage is applied for 5000 hours at 105°C.										
	Capacitance change	Within $\pm 20\%$ of the initial capacitance value									
tan δ	200% or less than the initial specified value										
Leakage current	Less than or equal to the initial specified value										
Shelf Life	After storing the capacitors under no load at 105°C for 1000 hours and then performing voltage treatment based on JIS C 5101-4 clause 4.1 at 20°C, they shall meet the specified values for the endurance characteristics listed above.										
Marking	Black print on the case top.										

Chip Type

Type numbering system (Example : 50V 330 μ F)

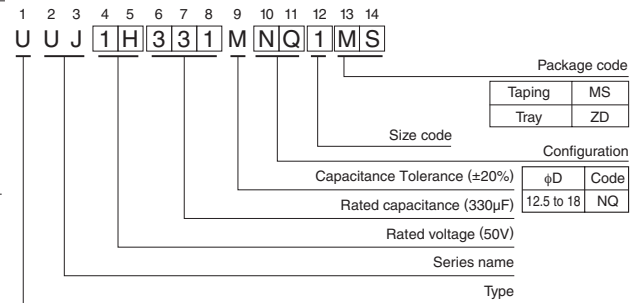
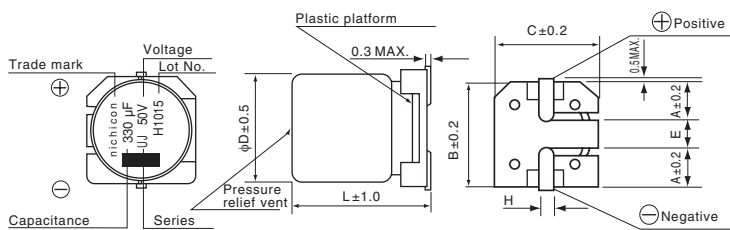

(mm)

ϕ D	12.5x13.5	12.5x16	12.5x21	16x16.5	16x21.5	18x16.5	18x21.5
A	4.8	4.8	4.8	5.4	5.4	6.4	6.4
B	13.6	13.6	13.6	17.1	17.1	19.1	19.1
C	13.6	13.6	13.6	17.1	17.1	19.1	19.1
E	4.0	4.0	4.0	6.3	6.3	6.3	6.3
L	13.5	16.0	21.0	16.5	21.5	16.5	21.5
H	1.0 to 1.4	1.0 to 1.4	1.0 to 1.4	1.0 to 1.4	1.0 to 1.4	1.0 to 1.4	1.0 to 1.4

※ The vibration structure-resistant product is also available upon request, please ask for details.

● Dimension table in next page.



■ Dimensions

(μF) Cap.	Code	V 6.3		10		16		25		35		50	
		0J		1A		1C		1E		1V		1H	
220	221									12.5 × 13.5	280	12.5 × 16	320
330	331							12.5 × 13.5	320	12.5 × 16	360	● 16 × 16.5	440
470	471					12.5 × 13.5	360	12.5 × 16	400	● 16 × 16.5	490	△ 18 × 16.5	550
1000	102	12.5 × 13.5	440	12.5 × 16	500	● 16 × 16.5	630	△ 18 × 16.5	700	△ 18 × 16.5	750	18 × 21.5	820
2200	222	● 16 × 16.5	750	● 16 × 16.5	810	△ 18 × 16.5	930	18 × 21.5	1050	□ 18 × 21.5	1150		
3300	332	△ 18 × 16.5	930	△ 18 × 16.5	1000	18 × 21.5	1150						
4700	472	18 × 21.5	1100	18 × 21.5	1200								
6800	682	□ 18 × 21.5	1350	□ 18 × 21.5	1450								

(μF) Cap.	Code	V 63		100		160		200		250		400		450	
		1J		2A		2C		2D		2E		2G		2W	
3.3	3R3													12.5 × 13.5	40
4.7	4R7									12.5 × 13.5	65	12.5 × 16	50	12.5 × 16	50
10	100							12.5 × 13.5	80	12.5 × 16	105	16 × 16.5	85	16 × 16.5	85
22	220							12.5 × 16	105	● 16 × 16.5	180	18 × 21.5	130	18 × 21.5	130
33	330					12.5 × 13.5	95	● 16 × 16.5	220	△ 18 × 16.5	230	□ 18 × 21.5	160	□ 18 × 21.5	160
47	470			12.5 × 13.5	160	● 16 × 16.5	260	△ 18 × 16.5	270	18 × 21.5	280				
68	680	12.5 × 13.5	175	12.5 × 16	205	△ 18 × 16.5	320	18 × 21.5	330	□ 18 × 21.5	340				
100	101	12.5 × 16	225	● 16 × 16.5	285	16 × 21.5	380	□ 18 × 21.5	410						
220	221	● 16 × 16.5	385	△ 18 × 16.5	440										
330	331	△ 18 × 16.5	490	□ 18 × 21.5	500										
470	471	18 × 21.5	590											Case size φD × L (mm)	Rated ripple

□: In this case, [6] will be put at 12th digit of type numbering system.

Size φ12.5×21L is available for capacitors marked "●".
Size φ16×21.5L is available for capacitors marked "△".

Rated ripple current (mArms) at 105°C 120Hz

● Frequency coefficient of rated ripple current

V	Cap.(μF)	Frequency				
		50Hz	120Hz	300Hz	1kHz	10kHz or more
6.3 to 100	47 to 68	0.75	1.00	1.35	1.57	2.00
	100 to 470	0.80	1.00	1.23	1.34	1.50
	1000 to 6800	0.85	1.00	1.10	1.13	1.15
160 to 450	3.3 to 100	0.80	1.00	1.25	1.40	1.60

- Taping specifications are given in page 23.
- Recommended land size, soldering by reflow are given in page 18, 19.
- Please refer to page 3 for the minimum order quantity.

Mouser Electronics

Authorized Distributor

Click to View Pricing, Inventory, Delivery & Lifecycle Information:

Nichicon:

[UUG2W4R7MNQ1ZD](#) [UUJ2A680MNQ1MS](#) [UUJ1H471MNQ1MS](#) [UUJ2W4R7MNQ1MS](#) [UUJ2A221MNQ1MS](#)
[UUJ0J102MNQ1MS](#) [UUJ0J222MNQ1MS](#) [UUJ0J222MNQ6MS](#) [UUJ0J332MNQ1MS](#) [UUJ0J332MNQ3MS](#)
[UUJ0J332MNQ6MS](#) [UUJ0J472MNQ1MS](#) [UUJ0J472MRQ6MS](#) [UUJ0J682MRQ1MS](#) [UUJ1A102MNQ1MS](#)
[UUJ1A222MNQ1MS](#) [UUJ1A222MNQ6MS](#) [UUJ1A332MNQ1MS](#) [UUJ1A332MNQ6MS](#) [UUJ1A472MNQ1MS](#)
[UUJ1A682MRQ1MS](#) [UUJ1C102MNQ1MS](#) [UUJ1C102MNQ6MS](#) [UUJ1C222MNQ1MS](#) [UUJ1C222MQ6MS](#)
[UUJ1C332MNQ1MS](#) [UUJ1C471MNQ1MS](#) [UUJ1E102MNQ1MS](#) [UUJ1E102MNQ6MS](#) [UUJ1E222MNQ1MS](#)
[UUJ1E331MNQ1MS](#) [UUJ1E471MNQ1MS](#) [UUJ1H102MNQ1MS](#) [UUJ1H221MNQ1MS](#) [UUJ1H331MNQ1MS](#)
[UUJ1H331MNQ6MS](#) [UUJ1H471MNQ6MS](#) [UUJ1J101MNQ1MS](#) [UUJ1J221MNQ1MS](#) [UUJ1J221MNQ6MS](#)
[UUJ1J331MNQ1MS](#) [UUJ1J331MNQ6MS](#) [UUJ1J471MNQ1MS](#) [UUJ1J680MNQ1MS](#) [UUJ1V102MNQ1MS](#)
[UUJ1V102MNQ6MS](#) [UUJ1V221MNQ1MS](#) [UUJ1V222MRQ1MS](#) [UUJ1V331MNQ1MS](#) [UUJ1V471MNQ1MS](#)
[UUJ1V471MNQ6MS](#) [UUJ2A101MNQ1MS](#) [UUJ2A101MNQ6MS](#) [UUJ2A221MNQ6MS](#) [UUJ2A331MRQ1MS](#)
[UUJ2A470MNQ1MS](#) [UUJ2C101MNQ1MS](#) [UUJ2C101MRQ6MS](#) [UUJ2C330MNQ1MS](#) [UUJ2C470MNQ1MS](#)
[UUJ2C470MNQ6MS](#) [UUJ2C680MNQ1MS](#) [UUJ2C680MNQ6MS](#) [UUJ2D100MNQ1MS](#) [UUJ2D101MRQ1MS](#)
[UUJ2D220MNQ1MS](#) [UUJ2D330MNQ1MS](#) [UUJ2D330MNQ6MS](#) [UUJ2D470MNQ1MS](#) [UUJ2D470MNQ6MS](#)
[UUJ2D680MNQ1MS](#) [UUJ2D680MRQ6MS](#) [UUJ2E100MNQ1MS](#) [UUJ2E220MNQ1MS](#) [UUJ2E220MNQ6MS](#)
[UUJ2E330MNQ1MS](#) [UUJ2E330MNQ6MS](#) [UUJ2E470MNQ1MS](#) [UUJ2E470MRQ6MS](#) [UUJ2E4R7MNQ1MS](#)
[UUJ2E680MRQ1MS](#) [UUJ2G100MNQ1MS](#) [UUJ2G220MNQ1MS](#) [UUJ2G330MRQ1MS](#) [UUJ2G4R7MNQ1MS](#)
[UUJ2W100MNQ1MS](#) [UUJ2W220MNQ1MS](#) [UUJ2W330MNQ1MS](#) [UUJ2W3R3MNQ1MS](#) [UUJ2G100MNQ1ZD](#)
[UUJ1V221MNQ1ZD](#) [UUJ1J221MNQ1ZD](#) [UUJ1H331MNQ1ZD](#) [UUJ1C471MNQ1ZD](#) [UUJ2W330MRQ1ZD](#)
[UUJ1H102MNQ1ZD](#) [UUJ1V102MNQ1ZD](#) [UUJ2C330MNQ1ZD](#) [UUJ1A222MNQ1ZD](#) [UUJ2D330MNQ1ZD](#)